



**Bio-Gel® P**  
**Polyacrylamide Gel**  
**Instruction Manual**

**BIO-RAD**



# Table of Contents

<b>Section 1</b>	<b>Introduction.....</b>	<b>1</b>
<b>Section 2</b>	<b>Technical Description .....</b>	<b>3</b>
<b>Section 3</b>	<b>Instructions for Use .....</b>	<b>6</b>
3.1	Column Selection .....	6
3.2	Eluant Selection.....	6
3.3	Preparation of the Gel.....	8
<b>Section 4</b>	<b>Sample.....</b>	<b>12</b>
<b>Section 5</b>	<b>Void Volume Determination and Calibration ....</b>	<b>14</b>
<b>Section 6</b>	<b>Sanitation and Sterilization .....</b>	<b>15</b>
<b>Section 7</b>	<b>Storage .....</b>	<b>15</b>
<b>Section 8</b>	<b>Flow Rate Determination .....</b>	<b>16</b>
<b>Section 9</b>	<b>Ordering Information.....</b>	<b>18</b>

# Section 1

## Introduction

Bio-Gel P gels are porous polyacrylamide beads prepared by copolymerization of acrylamide and N,N'-methylene-bis-acrylamide. The gels are extremely hydrophilic and essentially free of charge, and provide efficient, gentle gel filtration of sensitive compounds. Their synthetic composition and freedom from soluble impurities preclude eluate contamination. High resolution is assured by consistent narrow distribution of bead diameters and excellent molecular weight discrimination.

Bio-Gel P gel is compatible with dilute organic acids, 8 M urea, 6 M guanidine-HCl, chaotropic agents, reducing agents such as dithiothreitol and mercaptoethanol, and detergents such as SDS, CHAPS, and Triton® X-100. Bio-Gel P gel may be used effectively with distilled water however, buffers of > 50 mM ionic strength are recommended for most protein separations.

Miscible organic solvents may be added to the eluants used with Bio-Gel P gel. Alcohol up to 20% will not substantially alter the

exclusion properties of the gel, and will in some cases enhance separation of complex mixtures of poorly water soluble small molecules such as nucleotides, peptides, and tannins. Formamide may be used at full strength, because Bio-Gel P gel is completely swelled by this solvent.

Bio-Gel P gel is autoclavable at pH 5.5-6.0 in buffers such as 50 mM HEPES, MES, or citrate at 120 °C for 15-30 minutes. At room temperature, the recommended operating pH range is 2-10. Bio-Gel P gel is susceptible to hydrolysis of amide groups at higher or lower pH. Flow rate and resolution increase with temperature over the range of 4-80 °C.

## Section 2 Technical Description

**Table 1. Bio-Gel P Gel Product Description**

<b>Matrix</b>	Bio-Gel polyacrylamide gel
<b>Particle size</b>	
Medium	90-180 µm
Fine	45-90 µm
Extra fine	< 45 µm
<b>Shipping medium</b>	Shipped dry
<b>Resistance</b>	
pH	2-10
Pressure	15 psi
Organic solvents	< 20%
Working temperature range	4-80 °C
Temperature limits	Autoclavable, at pH 5.5-6.5, 120 °C for 30 min
<b>Storage</b>	Dry, at room temperature; in c tilled water or aqueous buffer at 4 °C with 0.02% sodium az

**Table 2. Properties of Bio-Gel P-Gels**

<b>Gel</b>	<b>Particle Size Range, Hydrated Beads (<math>\mu\text{M}</math>)</b>	<b>Typical Hydrated Bed Volume, ml/g of Dry Gel</b>	<b>Typical Flow Rates (cm/hr)*</b>	<b>Typical Fractionation Range/Nominal Exclusion Limit (Daltons)**, †</b>
Bio-Gel P-2 Gel, Fine	45-90	3	5.0-10	100-1,800
Bio-Gel P-2 Gel, Extra Fine	< 45		<10	100-1,800
Bio-Gel P-4 Gel, Medium	90-180	4	15-20	800-4,000
Bio-Gel P-4 Gel, Fine	45-90		10.0-15	800-4,000
Bio-Gel P-4 Gel, Extra Fine	< 45		<10	800-4,000
Bio-Gel P-6 Gel, Medium	90-180	6.5	15-20	1,000-6,000
Bio-Gel P-6 Gel, Fine	45-90		10.0-15	1,000-6,000
Bio-Gel P-6 Gel, Extra Fine	< 45		<10	1,000-6,000
Bio-Gel P-6DG Gel	90-180	6.5	15-20	1,000-6,000
Bio-Gel P-10 Gel, Medium	90-180	7.5	15-20	1,500-20,000
Bio-Gel P-10 Gel, Fine	45-90		10.0-15	1,500-20,000
Bio-Gel P-30 Gel, Medium	90-180	9	7.0-13	2,500-40,000
Bio-Gel P-30 Gel, Fine	45-90		6.0-11	2,500-40,000
Bio-Gel P-60 Gel, Medium	90-180	11	4.0-6	3,000-60,000
Bio-Gel P-60 Gel, Fine	45-90		3.0-5	3,000-60,000
Bio-Gel P-100 Gel, Medium	90-180	12	4.0-6	5,000-100,000
Bio-Gel P-100 Gel, Fine	45-90		3.0-5	5,000-100,000

\* Flow rates determined in a 1.5 x 70 cm column, using a hydrostatic pressure head:bed of 1:1.

\*\* Fractionation ranges above 40,000 daltons are for globular molecules.

† For quality control purposes, the exclusion limits are determined by calculating the  $K_D$ , or distribution coefficient. The distribution coefficient is a measure of the residence time of a molecule in the pores of the gel, and is expressed as:  $(V_e - V_o)/(V_t - V_o)$ , where  $V_e$  is the elution volume of the individual proteins,  $V_o$  is the void volume and  $V_t$  is the total available volume measured by a small molecule such as vitamin B<sub>12</sub>.

## Section 3

### Instructions For Use

#### 3.1 Column Selection

The ideal column dimensions will be those that allow baseline resolution of analytes without significant sample dilution. Typically, the column length to diameter ratio will be between 5 and 10 and a bed volume 4 to 20 times the volume of the sample. The minimal dilution factor that can be obtained for an excluded substance is approximately 1.25. Difficult fractionation procedures generally require bed length to diameter ratios of 25 to 100 or greater and bed volumes 25 to 100 times the sample volume.

#### 3.2 Eluant Selection

The eluant chosen should provide maximum stability for labile sample solutes. The ionic strength should be at least 20 mM to eliminate the effect of small amounts of negatively charged groups on the gel. Using highly concentrated salt solutions may cause small changes in gel bed volume and exclusion limits.

Bio-Gel P gel is compatible with solubilizing and denaturing conditions used in molecular weight determinations such as 6 M guanidine-HCl, chaotropic agents, reducing agents such as dithiothreitol and mercaptoethanol, and detergents such as SDS, CHAPS, and Triton X-100.

Volatile buffer salts, for example pyridine, acetic acid, ammonium formate, or ammonium bicarbonate, may be employed if the final product must be free of buffer salts. These substances are easily removed from effluent fractions by lyophilization.

Removal of dissolved gases, primarily carbon dioxide, should be performed to prevent bubble formation within the system. This is done by aspirating the buffer in a vacuum flask either with a water aspirator or central vacuum source.

The use of eluants with pH above 10 or below 2 should be avoided to prevent hydrolysis of the gel. Strong oxidizing agents should be avoided because they will react with the gel and increase the content of charged groups on the matrix.

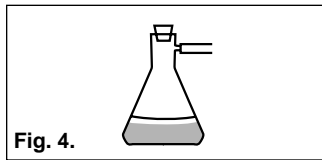
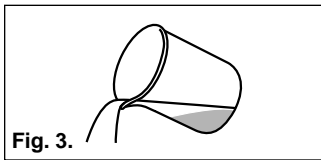
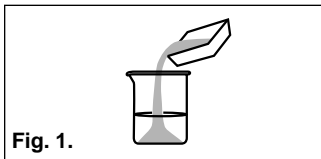

### 3.3 Preparation of the Gel

1. Gradually add dry Bio-Gel P media to buffer in a beaker. The amount of Bio-Gel P gel required to pack a column of known volume may be estimated by using the hydrated bed volume given in Table 2. Allow for gel loss during handling. Use twice as much buffer as the expected packed bed volume (Figure 1).

2. Allow Bio-Gel P-2 through P-10 gels to hydrate 4 hours at room temperature (1 hour if buffer was previously brought to 100 °C and then allowed to cool after addition of gel). Bio-Gel P through P-100 gels will require 12 hours at 20 °C, or 4 hours starting at 100 °C. After initial uniform suspension of beads is established, it is not necessary to stir; let settle during hydration (Figure 2).
3. After hydration is complete, decant half of supernatant (Figure 3). Transfer the solution to a filter flask and attach to a vacuum source. Degas the solution for 5-10 minutes with occasional swirling of the flask (Figure 4). Do not use a stir bar, as it can damage the gel.
4. Add two bed volumes of degassed buffer and swirl gently. Allow gel to settle until 90-95% of the particles have settled. Decant or remove supernatant by suction to remove fines. Repeat up to 4 times to remove > 90% of the fines.

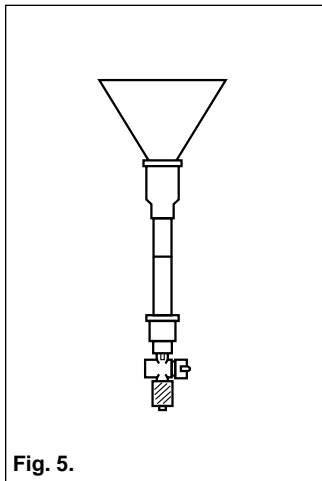

5. Affix a funnel to top of column, close column exit, and add enough buffer to fill 20% of column (Figure 5).

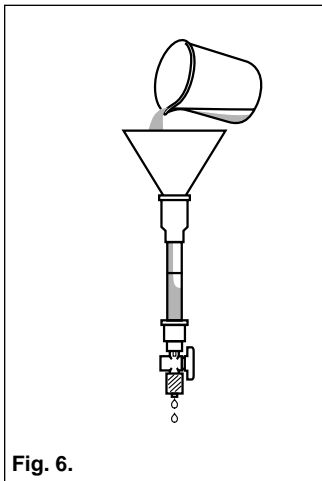

6. Pour the even slurry into the column in a single, smooth moment. Avoid splashing the slurry, to insure even packing, and avoid trapping air bubbles (Figure 6).
7. When a 2-5 cm bed has formed, allow column to flow until column is packed.
8. When the column is packed, close the column outlet and insert flow adaptor. Open the column outlet and pass 2 bed volume of buffer through the column at the operating flow rate.
9. Close the outlet and adjust the flow adaptor down to the level the gel bed. Load sample onto the upper bed surface by pump or injecting sample onto the gel bed through the flow adaptor; sample is injected, the injection flow rate should not exceed recommended elution flow rate.
10. If a flow adaptor is not to be used, remove excess gel to desired bed height once the column is packed and attach column to a reservoir. Pass 2 bed volumes of buffer through the column at the operating flow rate. Drain the buffer down to the level the gel bed and layer the sample carefully onto the upper surface, allowing it to drain into the bed. Follow this with ac

tional buffer to wash the sample into the bed. Replace the supernatant buffer and attach column to reservoir.

11. Collect fractions for analysis, or monitor with continuous flow equipment such as UV/Vis, conductivity, and refractive index monitors.

## Section 4 Sample

Gel filtration is largely independent of sample concentration. The volume of the sample relative to the bed volume is far more important. For analytical purposes the sample should not be larger than 1-5% of the bed volume, whereas for desalting the sample can be as large as 30-35% of the bed volume. The viscosity of the sample may limit the concentration of sample which can be used. Viscous samples may be diluted to decrease the viscosity. It may be possible to achieve better results by applying viscous samples at a lower flow rate. The sample should be clear, and completely dissolved in running buffer, without particles or solid contaminants. Filtration of samples will increase column life. If, due to the nature of the sample, it is not pos-

sible to filter it, the sample should be centrifuged until it is clear. Figure 7 shows the hypothetical effects of various chromatographic conditions.

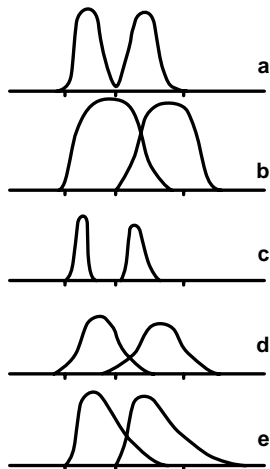

**Fig. 7. Aberations in gel chromatography elution profiles (hypothetical).**

**a.** Satisfactory separation. **b.** Sample volume too large or bed too short. **c.** Eluant flow rate too high or gel particle size too large. **d.** Poor sample application, nonuniform cross-sectional bed resistance, or large dead space volume. **e.** Sample viscosity too high.

## Section 5 Void Volume Determination and Calibration

The void volume ( $V_o$ ) of the bed is equal to the elution volume ( $V_e$ ) of excluded material. The void volume of the bed should be determined and the bed should be tested for uniformity of eluant flow before applying experimental sample. Colored proteins such as hemoglobin or ferritin are convenient for this procedure. Blue dextran is not recommended for  $V_o$  determination because it is heterogeneous and may give variable results. It also may bind nonspecifically to the gel.

Using standard protein allows verification of the column packing and protein elution. It also allows comparison of different columns, and different packing material, without wasting precious sample. Bio-Rad's Gel Filtration Standard is a mixture of five proteins with known relative molecular weights; thyroglobulin ( $M_r$  670,000), bovine gamma globulin ( $M_r$  158,000), chicken ovalbumin ( $M_r$  44,000), equine myoglobin ( $M_r$  17,000), and vitamin B<sub>12</sub> ( $M_r$  1,350). Vitamin B<sub>12</sub>

and myoglobin are visible and can be seen as they migrate through column.

## Section 6 Sanitation and Sterilization

Bio-Gel P gel can be sterilized within a column by using hydrogen peroxide in water, ethanol solutions (the gel will shr slightly in alcohol), diethyl pyrocarbonate, or thimerosal 1:10,0. Hydrated Bio-Gel P gel can be autoclaved at pH 5.5-6.5, at 120 for 30 minutes. When autoclaving, the gel may swell 4-25 times original volume. Swelling increases with increased pore size.

## Section 7 Storage

Packed columns of Bio-Gel P gel can be stored indefinitely maintained at neutral pH in the presence of a bacteriostat such 0.02% sodium azide. Packed columns should be stored at 4 °C.

## Section 8 Flow Rate Determination

Gel filtration is a diffusion controlled process: the efficiency of resolution depends on flow rate and gel bead size uniformity. Highest resolution is obtained when the flow rate is maintained in the range of 2-10 cm/hr.\*\* For a linear flow rate of 5 cm/hr, corresponding column flow rates are obtained by multiplying by the column cross sectional area:

**Table 3. Flow Rate Determination**

<b>Recommended Linear Flow Rate* cm/hr**</b>	<b>Column Diameter</b>	<b>Cross Sectional Area (cm<sup>2</sup>)</b>	<b>Column Flow Rate ml/hr</b>
5	0.7	0.385	1.9
5	1.0	0.785	3.9
5	1.5	1.77	8.9
5	2.5	4.91	25
5	5.0	19.6	98

\* In a 1.5 x 70 cm column. Flow rates will decrease with increasing column length.

\*\* ml/hr/cm<sup>2</sup> (cross sectional area) = cm<sup>3</sup>/hr/cm<sup>2</sup> = cm/hr

Increases in column diameter (cross sectional area) dramatically increase throughput and flow rate (ml/hr). Maximum resolution is achieved with the smallest bead diameter ranges (extra fine or 1 sizes). The highest flow rates are obtained with the medium size beads. The flow rate and resolution desired for the application, well as exclusion limit and fractionation range, should be considered when selecting the appropriate gel filtration matrix.

Econo-Column<sup>®</sup> glass chromatography columns are ideally suited for use with Bio-Gel gel filtration media. The standard Econo-Column chromatography columns come in six diameters, ranging from 0.5 to 5.0 cm, with lengths from 4 to 170 cm. These columns are autoclavable and possess a bed support which can retain particles greater than 20 µm. Note that some extra fine bead sizes for Bio-Gel P gel are not compatible with Econo-Column chromatography columns. For Econo-Column column and accessory ordering information, consult the Bio-Rad catalog.

## Section 9

### Ordering Information

<b>Catalog Number</b>	<b>Product Description</b>	<b>Comments</b>
150-4114	Bio-Gel P-2 Gel, Fine, 100 g	Rapid carbohydrate and small peptide separations and desalting. Fractionation range of 100-1,800.
150-4115	Bio-Gel P-2 Gel, Fine, 500 g	
150-4118	Bio-Gel P-2 Gel, Extra Fine, 100 g	
150-4120	Bio-Gel P-4 Gel, Medium, 100 g	Rapid carbohydrate and small peptide separations and desalting. Fractionation range of 800-4,000.
150-4124	Bio-Gel P-4 Gel, Fine, 100 g	
150-4128	Bio-Gel P-4 Gel, Extra Fine, 100 g	
150-4130	Bio-Gel P-6 Gel, Medium, 100 g	Purification of proteins and polypeptides. Fractionation range of 1,000-6,000.
150-4134	Bio-Gel P-6 Gel, Fine, 100 g	
150-4138	Bio-Gel P-6 Gel, Extra Fine, 100 g	
150-0738	Bio-Gel P-6DG Gel, 100 g	Gel most highly suited for protein desalting or buffer exchange. Fractionation range of 1,000-6,000. Also available in prepacked columns and cartridges.
150-0739	Bio-Gel P-6DG Gel, 1 kg	
150-4140	Bio-Gel P-10 Gel, Medium, 100 g	Purification of proteins and polypeptides. Fractionation range of 1,500-20,000.
150-4144	Bio-Gel P-10 Gel, Fine, 100 g	

<b>Catalog Number</b>	<b>Product Description</b>	<b>Comments</b>
150-4150 150-4154	Bio-Gel P-30 Gel, Medium, 100 g Bio-Gel P-30 Gel, Fine, 100 g	Purification of proteins and polypeptides. Fractionation range of 2,500-40,000.
150-4160 150-4164	Bio-Gel P-60 Gel, Medium, 100 g Bio-Gel P-60 Gel, Fine, 100 g	Purification of proteins and polypeptides. Fractionation range of 3,000-60,000.
150-4170 150-4174	Bio-Gel P-100 Gel, Medium, 100 g Bio-Gel P-100 Gel, Fine, 100 g	Purification of proteins and polypeptides. Fractionation range of 5,000-100,000.
151-1901	Gel Filtration Standard	Contains thyroglobulin (5 mg), bovine gamma globulin (5 mg), chicken oval min (5 mg), equine myoglobin (2.5 mg), and vitamin B <sub>12</sub> , 0.5 (mg).

Triton® is a registered trademark of Rohm and Haas.

*Bio-Rad Laboratories, 2000 Alfred Nobel Dr., Hercules, CA 94547*

**LIT174 Rev B**